



62A12-1 Hi-Fi Expansion Kit

Installation Manual



Music that can live anywhere

Easy to operate. Enjoy music regardless of where it lives, anywhere in the house (i.e. simply push the volume knob to select your living room CD player as a source of music as you relax on your patio and then use your CD remote to control the song selection or volume without getting up from your lawn chair!).

High Fidelity performance that's affordable. More power and flexibility than "amplified keypad" systems at similar cost.

First built-in unit with remote input module. Your music can be located anywhere instead of in an audio rack. Wiring to the main unit is hidden for a neat installation.

Description

This kit expands the HAI Hi-Fi Whole Home Audio Distribution System from 4 Zones and 4 Sources to a full 8 Zone, 6 Source system.

Features:

- Adds an additional 4 zones of audio and 2 audio sources throughout your home
- Modular Zone Amplifier Cards plug into the Hi-Fi Main Board Assembly
- Remote Input Modules (RIM) and Volume-Source Control (VSC) Units connect using Standard Category 5 Wiring

Includes:

- 4 Zone Amplifier Cards
- 2 Remote Input Modules (RIM) with 2 IR Flashers
- 4 Volume and Source-Control (VSC) Units
- Power Supply that powers 4 zone amplifiers
- Manual

Installing Remote Input Modules (RIM)

All audio sources are connected directly to Remote Input Modules (RIM) in rooms that will have music sources. Remote Input Modules connect directly to the Hi-Fi Main Assembly using Cat 5, unshielded, twisted pair (UTP) for communications. Each end of the wire is terminated with an RJ45 connector. The correct wiring scheme for the Cat 5 cable is standard EIA/TIA 568A. Properly terminating the Cat 5 cable is crucial for the operation of the system.

It is best that no single run of Cat 5 exceeds 500 feet.

Insert the RJ45 connector on one end of the cable to the respective source input jack (1-6) under “Remote Audio In / IR Out” on the Hi-Fi Main Assembly. Insert the RJ45 connector on the other end of the cable to the jack labeled “Remote Audio” on the RIM.

Changing the Color of the RIM

The color of the RIM may be changed to complement the interior décor. The RIM is supplied with a white faceplate and insert. Additional colors are available; contact your HAI distributor for more information. Change the color of the RIM as follows:

1. Remove the faceplate.
2. The insert attaches to the RIM with one latch on the right and one on the left. Using a small-bladed screwdriver, gently depress the latch on one side while lifting up on the insert. Once the latches are released on one side, remove the insert from the other side.
3. Align the latches of the new insert to the openings on the RIM and gently snap into place.
4. Attach the new faceplate.

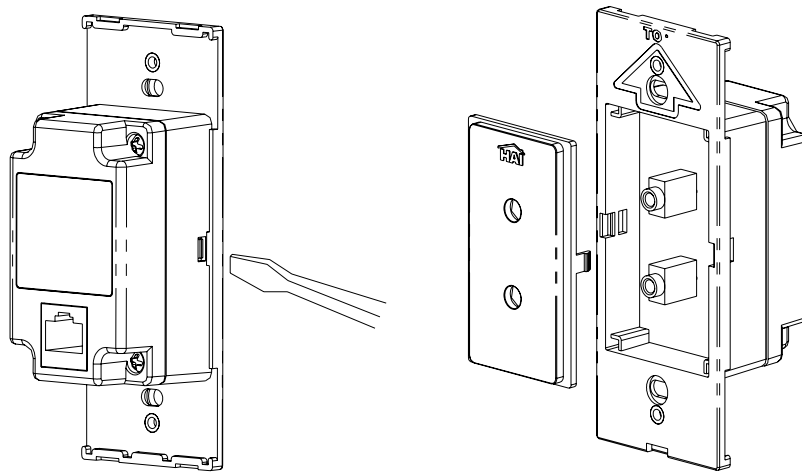

Setting the Frequency of the IR Output

When using the RIM to send IR data to source equipment, there are two different IR carrier frequencies in which the RIM can transmit the IR signal. The default setting of 38 kHz is used for most audio sources. However, most cable and satellite converter boxes operate at a higher IR carrier frequency closer to 56 kHz. Each RIM has a jumper that allows you to change the frequency of the IR output when using such devices.

To change the frequency setting, remove the faceplate and insert from the RIM as described under “Changing the Color of the RIM”.

Once The Insert Has Been Removed, Move The Frequency Jumper (CN1) From The “38khz” Position To The “56khz” Position.

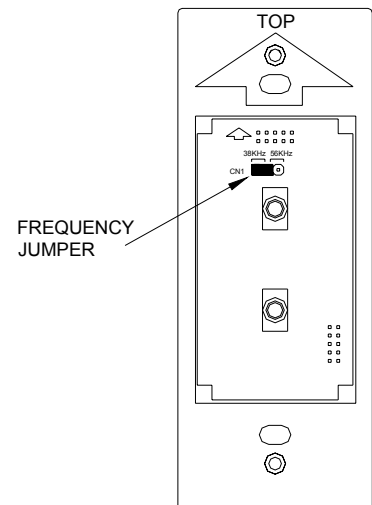

IR Output

Each RIM ships with an IR flasher (62A08-1). The IR flasher is used for sending IR data to the source equipment. When you point your source equipment remote control at the IR receiver in the VSC and send a signal, the IR data is routed to the appropriate RIM (to which the source is connected), which then sends the IR signal through the IR flasher to the source equipment.

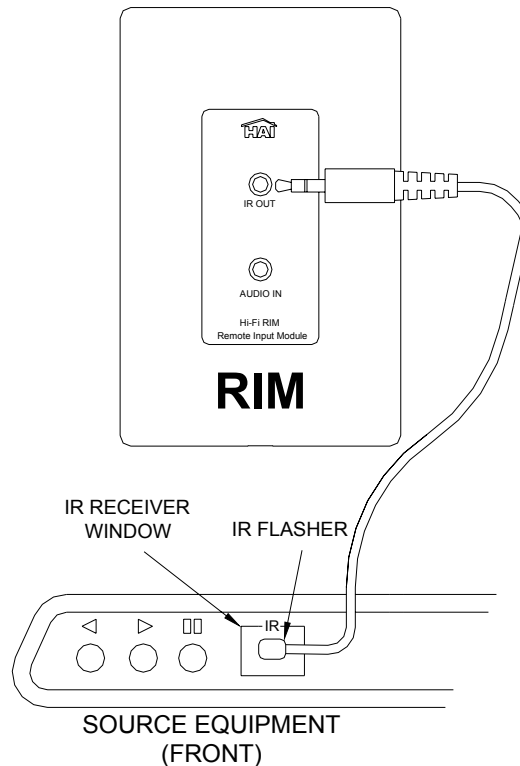

Installing Volume-Source Control (VSC) Units

The audio sources can be selected and controlled by any Volume-Source Control (VSC). Additionally, each VSC include an IR receiver that allows you to remotely control the Hi-Fi system and/or audio sources from any zone in the house. Volume-Source Control (VSC) Units connect directly to the Hi-Fi Main Assembly using Cat 5, unshielded, twisted pair (UTP) for communications. Each end of the wire is terminated with an RJ45 connector. The correct wiring scheme for the Cat 5 cable is standard EIA/TIA 568A. Properly terminating the Cat 5 cable is crucial for the operation of the system.

The total distance of Cat 5 between the Hi-Fi Main Assembly and the VSC units must not exceed 2000 feet. It is best that no single run of Cat 5 exceeds 250 feet.

Insert the RJ45 connector on one end of the cable to zone input jack (1-8) under “Zone Control / IR In” on the Hi-Fi Main Assembly. Insert the RJ45 connector on the other end of the cable to the jack labeled “Zone Control” on the VSC.

Changing the Color of the VSC

The color of the VSC may be changed to complement the interior décor. The VSC is supplied with a white faceplate, knob, and insert. Additional colors are available; contact your HAI distributor for more information. Change the color of the RIM as follows:

1. Remove the faceplate. Firmly grasp the knob and pull straight outward until the knob is removed.
2. The insert attaches to the VSC with one latch on the right and one on the left. Using a small-bladed screwdriver, gently depress the latch on one side while lifting up on the insert. Once the latches are released on one side, remove the insert from the other side.
3. Align the latches of the new insert to the openings on the RIM and gently snap into place.
4. Insert the new knob onto the volume control shaft. Attach the new faceplate.

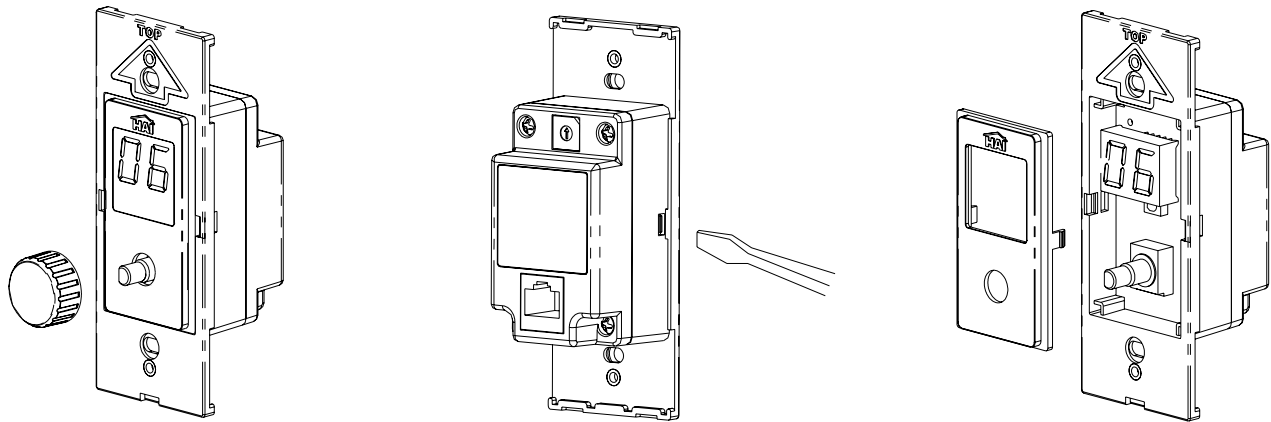

Setting the Zone Address

Although the Hi-Fi Main Assemble has separate RJ45 connectors for each zone, each VSC must be configured to a specific zone address to establish its location. This setting is made on the back of the VSC using a rotary switch. To set the zone address, place a small screwdriver in the slot on the rotary switch and turn it to the appropriate zone address number 1-8

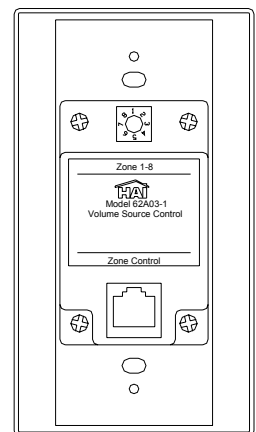

Speaker Wiring

When running the cables for speakers, use 16-gauge two-conductor or four-conductor (four-conductor stranded is recommended for neater installation) speaker wire. Speaker cable is homerun from the speaker location to the location of the Hi-Fi Main Assembly.

The Hi-Fi System is designed to work with one pair of speakers per zone.

Terminating Speaker Wires

Always observe proper orientation of the positive and negative signal for each speaker connection.

Typically, when using two-conductor speaker wire, the red wire indicates positive (+) and black wire indicates negative (-). Another indication of positive is a dark line running through the insulation.

Four-conductor wire can also be used and makes for a neater installation. Four-conductor wire has four separate wires in one outer jacket, making it possible to run a single speaker wire for a pair of zone speakers. This type of wire typically uses red and black for one speaker and white as positive and green as negative for the second speaker.

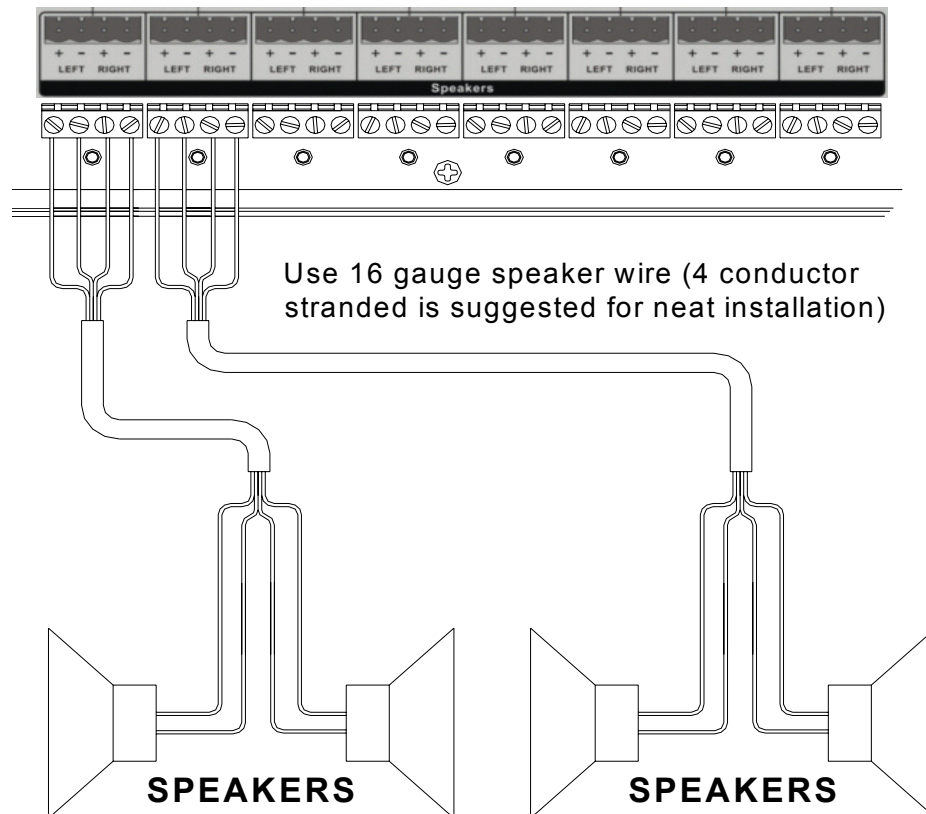

Installing Zone Amplifier Cards

Zone Amplifier Cards (ZAC) can be added at any time to increase the total number of zones to eight.

To install a Zone Amplifier Card:

- 1) Power down the Hi-Fi system by unplugging both Power Supply units (if applicable) from the inputs labeled "Power" on the Hi-Fi Main Assemble.
- 2) Pull upward on each of the 4 plungers until you hear them snap

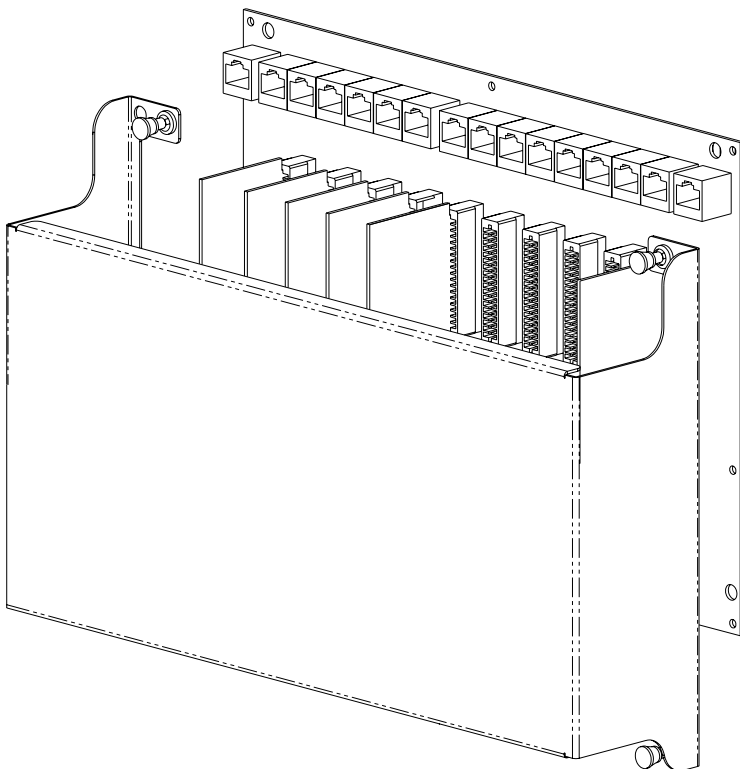
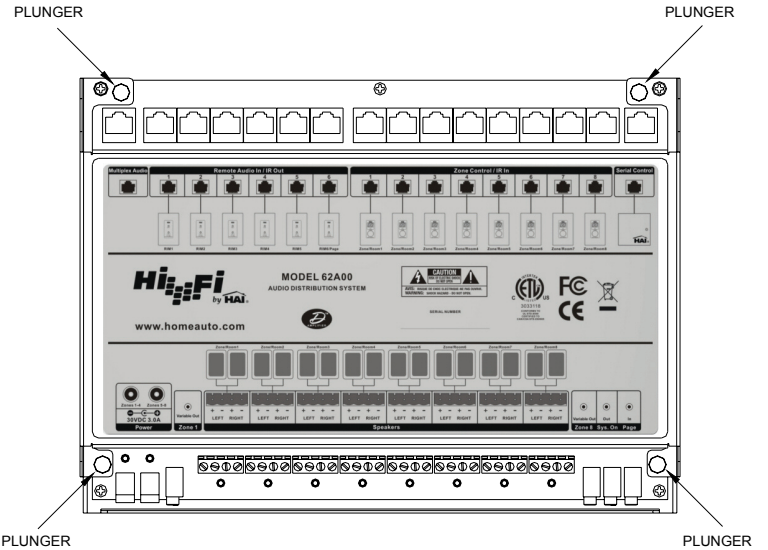

- 3) Remove the cover from the Hi-Fi Main Assembly by lifting it away from the Hi-Fi circuit board.

- 4) Install additional Zone Amplifier Cards in an empty connector (CN5-CN8) by positioning the Zone Amplifier Card directly over the connector and gently but firmly pushing down on both sides of the card until the top and bottom are securely seated into the connector.
- 5) Replace the cover by pushing down on each of the 4 plungers until you hear them snap.
- 6) Reconnect each Power Supply.

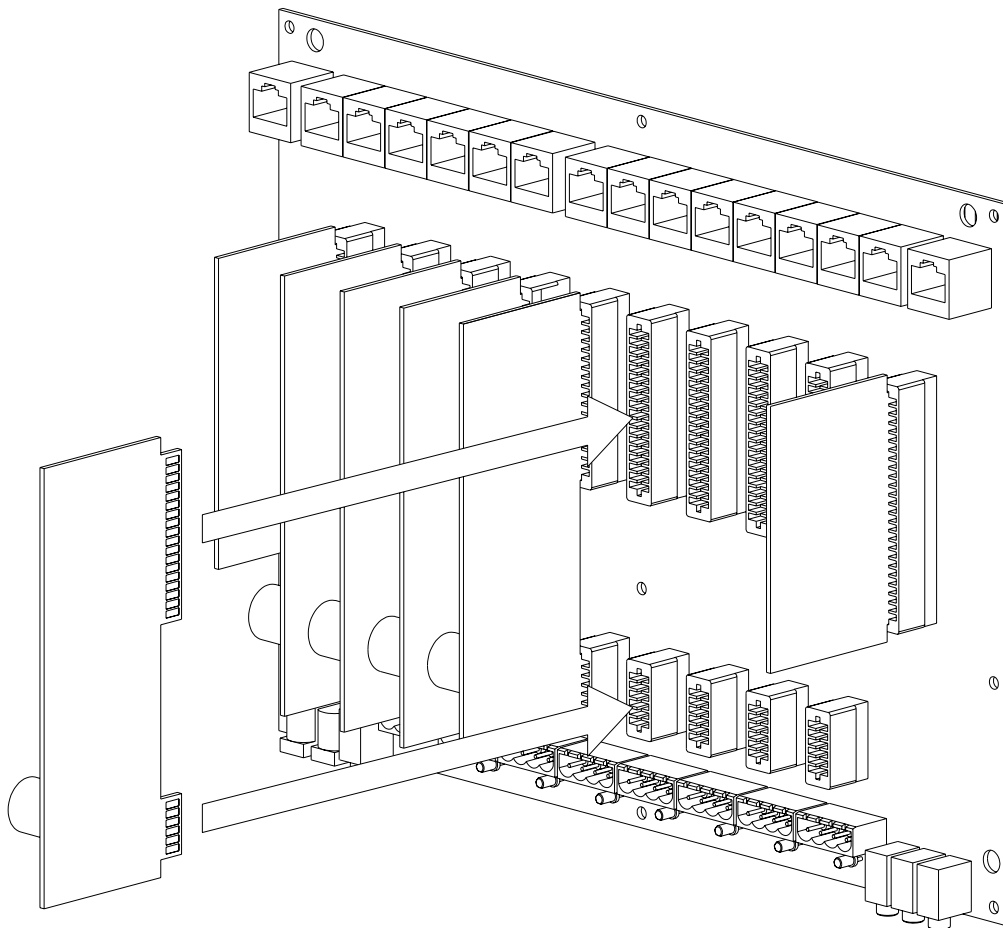

Powering the Hi-Fi System

The Power Supply (HAI Part Number: 62A07-1) powers the Hi-Fi processor and 4 Zone Amplifier Cards. One Power Supply is needed to power Zones 1-4 and a second Power Supply (supplied) is used to power Zones 5-8 (when connected to the Power jack on the right).

- 1) Insert the connector for the Power Supply into the Power jack marked “PJ1” (jack to the left) under the section labeled “Power Zones 1-4” on the Hi-Fi Main Assembly.
- 2) Plug the power cord from the Power Supply into a 120 VAC outlet. The “POWER ON” LED will illuminate. The Hi-Fi system will start. Follow the instructions in the User’s Guide for operation.
- 3) Insert the connector for the Power Supply into the Power jack marked “PJ2” (jack to the right) under the section labeled “Power Zones 5-8” on the Hi-Fi Main Assembly. Plug the power cord from the Power Supply into a 120 VAC outlet. The “POWER ON” LED will illuminate.

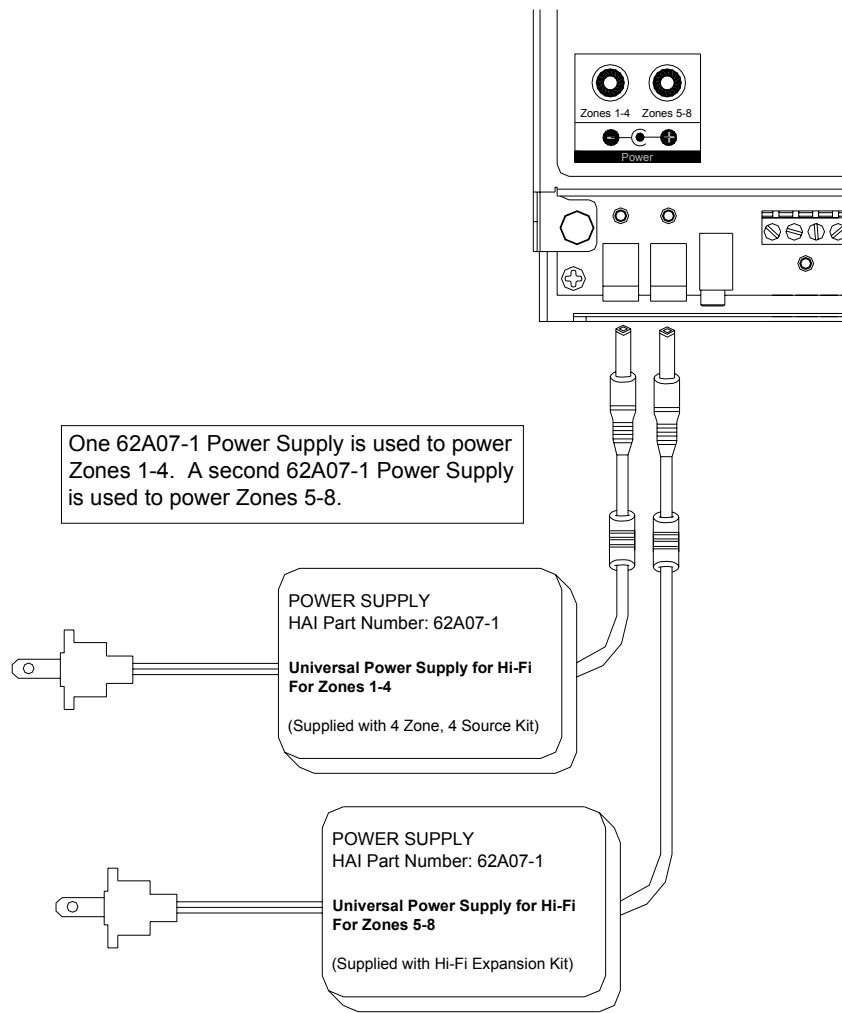

Specifications

Zones 1-8 Power Amplifier Outputs

Continuous Average Output Power:	30W (15W x 2) Two channels driven 30-20kHz @1% THD
Rated Distortion (1/2 power):	0.40%
Rated Impedance:	6 Ohms
Damping Factor:	50+
Frequency Response (20-20kHz):	±2dB

Preamplifier Section

Variable output:	0-600mV
Impedance:	600 Ohms

Source Inputs 1-6

Input Impedance:	10K
Input Sensitivity for rated power:	300mV RMS
Input Overload:	3V RMS

Emitter Outputs

Output Drive Current:	100mA
Output Drive Voltage:	5V

System

System On:	5V @ 50mA (Ring = Ground)
Page / Mute input:	Normally open (close to activate)

Power Requirements

Power Supply Input (each):	100-240VAC, 50/60Hz, 120W
Power Supply Output (each):	30VDC, 3 Amps

Power Consumption

All channels driven to full-rated power:	240W
Average operating conditions:	30W
No signal:	Less than 10W

Physical Specifications

Unit Size (in enclosure):	13" W x 13" H x 4.5" D
Unit Size (on mounting plate):	13.25" W x 8.5" H x 3.75" D
Unit Weight (in enclosure):	14 lb.
Unit Weight (on mounting plate):	8 lb.



HAI • New Orleans, LA • U S A